

1000  
PSI

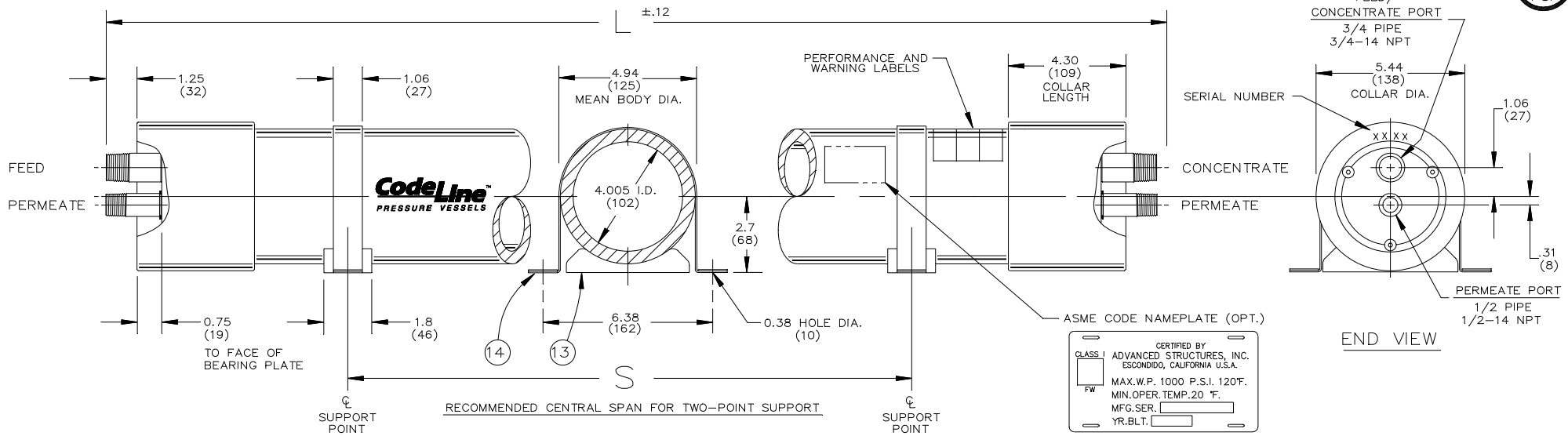

Dwg. Ref.	Qty. Per	Part Number	Part Name	Materials/Remarks
SHELL				
①	1	1040XX-	Shell Length	Filament wound epoxy/glass composite with head locking groove formed by adhesive-bonded 6061-T6 hd. anod. Al. alloy collar
END PLUG ASSY				
②	2	404001-3	Bearing Plate	6061-T6 hard anodized Al. alloy
③	2	404002-1	Sealing Plate	PVC Thermoplastic
④	2	404003-2	Feed/Conc Port	Superaustenitic stainless steel - 6% moly.
⑤	2	204007-1	Permeate Port	PVC Thermoplastic
⑥	2	404008-1	Port Retainer Set	Type 316 SST-2 identical pieces per set
⑦	2	6CR001-87	Retaining Ring	Ph 15-7 Mo SST
⑧	2	6ER001-342	Plug Seal	Ethylene propylene O-Ring
⑨	4	6ER001-120	Port Seal	Ethylene propylene O-Ring
⑩	2	6ER001-116	PWT Seal	Ethylene propylene O-Ring
END PLUG INTERLOCK				
⑪	2	404007-1	Plate Retainer Set	6061-T6 hd. anod. - 3 distinct pieces/set
⑫	6	1CF005-1	Buttonhead Screw	18-8 SST with thread lock patch
VESSEL SUPPORT				
⑬	2	404056-1	Saddle	Cast urethane elastomer
⑭	2	204004-3	Strap	Type 304 SST - PVC cushion
FOR REFERENCE ONLY				

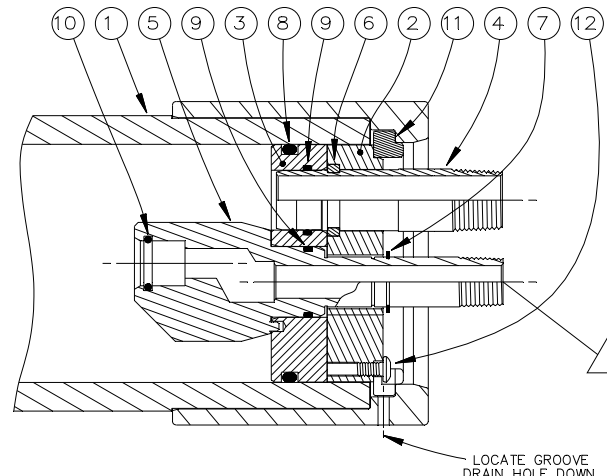

SECTION THROUGH END CLOSURE

⚠ INTERNAL PORT PRESSURE MUST NOT EXCEED 125 PSI

⚠ WARNING!

• DIMENSIONS IN INCHES (MM APPROX)  
• NOT TO BE USED FOR CONSTRUCTION UNLESS CERTIFIED

Shell Length Code	L L.O.A. IN (MM)	S Span IN (MM)	Empty Weight LB (KG)
A1	51.0 (1295)	Any	30 (14)
C1	32.0 (813)	Any	18 (8)

**CodeLine™**  
PRESSURE VESSELS  
by  
**CodeLine DIVISION**  
**STRUCTURAL NORTH AMERICA**  
Escondido, California U.S.A.

ENGR AP 04SEP97	MODEL U4S SEAWATER RO PRESSURE VESSEL (DIRECT CONNECT)				
QLTY JK 09SEP97					
MRKT DWE 06SEP97	SCALE NONE	SHEET 1 OF 1	SIZE B	NUMBER 504003	REV F

## RATING:

DESIGN PRESSURE..... 1000 PSI at 120°F  
(6.9 MPa at 49°C)  
 MIN. OPERATING TEMP..... 20°F  
(-7°C)  
 FACTORY TEST PRESSURE..... 1500 PSI  
(10.3 MPa)  
 BURST PRESSURE..... 6000 PSI  
(41.4 MPa)

## INTENDED USE

The Model U4S Seawater RO Pressure Vessel is designed for continuous, long-term use as a housing for reverse osmosis membrane elements to desalt typical brackish waters at pressures up to 1000 psi. Any make of 4-inch nominal diameter spiral-wound element with a 3/4" diameter male product water tube is easily accommodated.

The Model U4S is designed in accordance with the engineering standards of the Boiler and Pressure Vessel Code of the American Society of Mechanical Engineers (ASME Code). At small additional cost, vessels can be inspected during construction by an ASME Authorized Inspector and ASME Code stamped.

The Model U4S must be installed, operated and maintained in accordance with the precautions listed, and good industrial practice to assure safe operation over a long service life.

The high performance reinforced plastic shell must be allowed to expand under pressure; undue restraint at support points or piping connections can cause leaks to develop in the shell. The end closure, incorporating close-fitting, interlocking metal components, must be kept dry and free of corrosion; deterioration can lead to catastrophic mechanical failure of the end plug.

Advanced Structures, Inc. will assist the purchaser in determining the suitability of this standard vessel for their specific operating conditions. The final determination however, including evaluation of the standard materials of construction for compatibility with the specific corrosive environment, shall be the responsibility of the purchaser. Alternate materials with enhanced corrosion resistance are available on special order.

Specifications subject to change without notice.

## PRECAUTIONS

- DO... read, understand and follow all instructions; failure to take every precaution will void warranty and may result in vessel failure
- DO... mount shell with drain holes down on horizontal members at central span "S" using compliant vessel supports furnished; tighten holddown straps just snug
- DO... provide overpressure protection for vessel set at not more than 105% of design pressure
- DO... inspect end closures regularly; replace components that have deteriorated and correct causes of corrosion
- DO NOT... make rigid piping connections to ports or clamp vessel in any way that restricts growth of fiberglass shell under pressure; at design pressure  
▲ DIA = 0.001 in. (0.25mm) and ▲ = 0.2 in. (5mm) for a length code -6 vessel
- DO NOT... hang piping manifolds from ports or use vessel in any way to support other components
- DO NOT... operate vessel at pressures and temperatures in excess of its rating
- DO NOT... operate vessel without both permeate ports internally connected with a complete set of elements and interconnecting hardware
- DO NOT... operate vessel with permeate port pressure in excess of 125 psi at 120°F (0.9 Mpa at 49°C)
- DO NOT... tolerate leaks or allow end closures to be routinely wetted in any way
- DO NOT... pressurize vessel until double checking to verify that all three segments of Plate Retainer Set are in place and secured by all three screws at both ends.
- DO NOT... work on any component until first verifying that pressure is relieved from the vessel

### NOTE

5/32 in. hex key required to open and close vessel.

## ORDERING

Please specify the following:

- VESSEL MODEL NUMBER built from table of options below
- MEMBRANE ELEMENT MAKE AND MODEL NUMBER
- SPECIFIC CONCERNS regarding INTENDED USE and requests for SPECIAL MATERIALS of CONSTRUCTION

A vessel model number specifies a complete assembly less element interface components. The required interface components are furnished with the vessel but are specified separately.

Membrane elements and between-element connectors (interconnectors) are furnished by membrane element manufacturer.

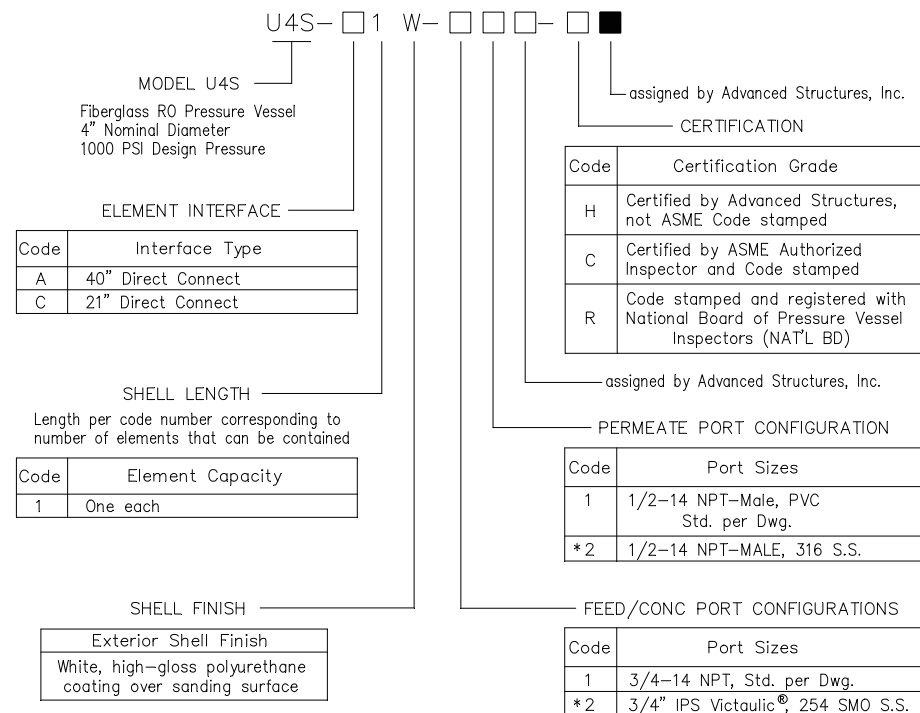

\* OPTIONAL - Consult factory for specifications and pricing

