

# PENTAIR® X-FLOW™ HFNANO UNIT

## PRODUCT DATASHEET

### GENERAL INFORMATION

Pentair® X-Flow™ HFNano Unit is a pre-engineered fully functional Nanofiltration (NF) unit, specifically designed to help meet the drinking water requirements of small communities and facilities. Net capacity ranges from 1.5 to 10 m<sup>3</sup>/hr, depending on unit size and feed water quality.

X-Flow HFNano Unit utilizes the uniquely designed Pentair X-Flow Hollow Fiber HFW1000 Hydrophilic Nanofiltration Membrane Elements. Typical applications are small capacity drinking water production from highly colored, surface water or treatment and reuse of wastewater.

### ABOUT HOLLOW FIBER NANOFILTRATION

The same dedication and advanced filtration expertise instilled in every Pentair X-Flow Ultrafiltration Membrane Element was applied to engineer the ideal nanofiltration membrane element. X-Flow Hollow Fiber HFW1000 Nanofiltration Membrane Element features a 1000 Dalton (Dextrane) MWCO separation top-layer. The membrane fiber diameter and high chemical resistance to chlorine, caustic and strong acids are similar to the well-known Pentair X-Flow Hollow Fiber Ultrafiltration Membrane Elements.

Unique combination of nanofiltration removal characteristics and Hollow Fiber membrane fibers help ensure:

- high removal of dissolved organic matter (NOM, DOC, UV254), turbidity and suspended solids
- certified for bacteria and viruses
- minimum removal of hardness and salts (Mg, Ca)
- high cleanability
- stable long-term performance
- no special pre-treatment being required other than a 200 micron strainer

### PENTAIR X-FLOW HFNANO UNIT

**Pentair X-Flow HFNano Unit:**  
**Integrated frame with multiple Pentair X-Flow HFW1000 Membrane Elements, crossflow circulation pump, chemical dosing sets and main control panel.**

### HORIZONTAL CONFIGURATION

In X-Flow HFNano Unit, X-Flow HFW1000 Membrane Elements are stacked horizontally in multiples of three elements in series in one rack, by direct connection of the feed and concentrate ports of the membrane element end-caps:

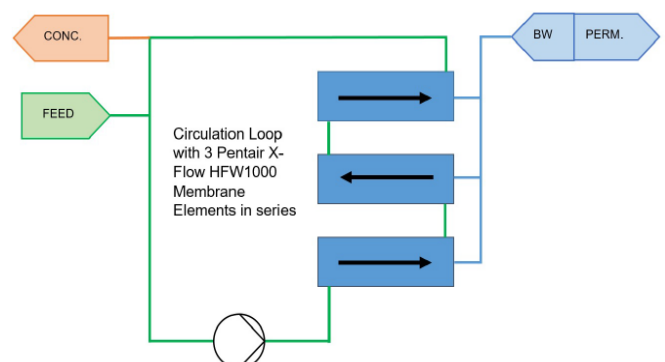

**Benefits**

- No need for membrane housings and headers
- Reduced design capacity of circulation pump
- Flow velocity in end-cap connections is sufficiently high to help avoid accumulation of solids/and fouling
- Optimum compact overall design and footprint, a fully functional unit fits inside a standard shipping container

**PROCESS FLOW DIAGRAM FOR PENTAIR X-FLOW HFNANO UNIT**

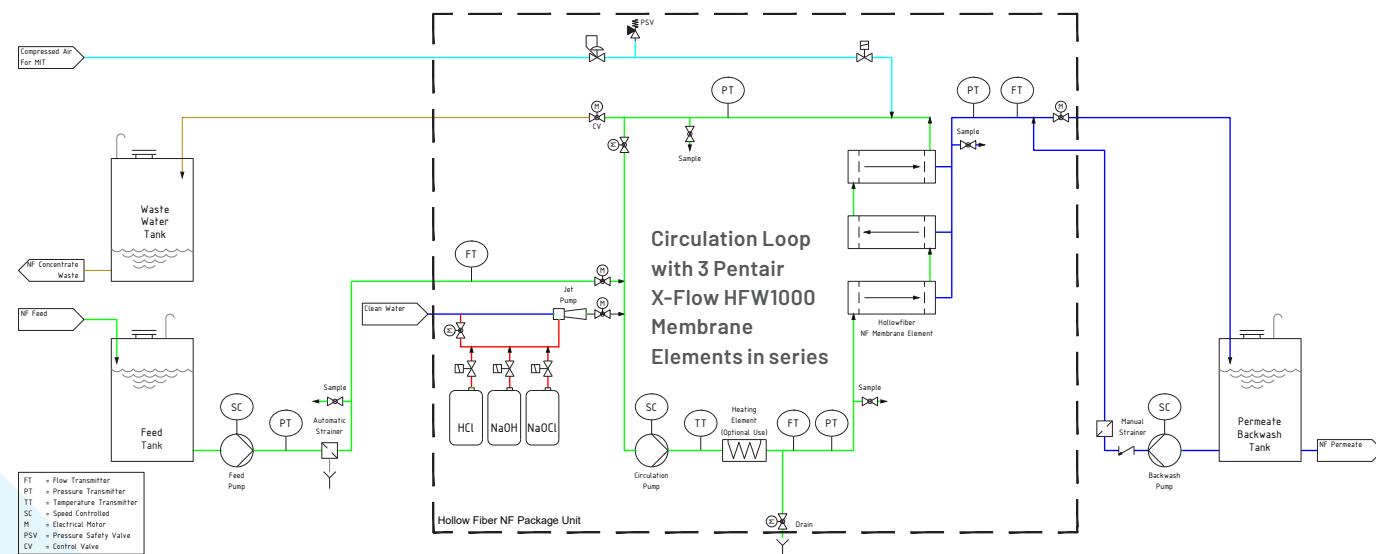

**Highlights HF Nano Process**

- Feed water to X-Flow HFNano Unit is supplied with a speed controlled feed pump to help enable adequate flow control during the HF Nano process operation, anticipating periodic flushing of the automatic feed strainer.
- X-Flow HFNano Unit is operated in low velocity crossflow using a speed controlled circulation pump.
- NF permeate produced by the X-Flow HFNano Unit is collected in a Permeate / Backwash tank.
- X-Flow HFNano Unit is automatically cleaned by a combination of forward flush (with feed pump) and backwash (with backwash pump).
- X-Flow HFNano Unit is Chemically Enhanced Cleaned (CEC) automatically with a combination of caustic, sodium hypochlorite and/or hydrochloric acid to restore the membranes to (initial) clean state.
- An electrical heating element is present in the circulation loop for improving the cleaning result if required.
- Wastewater from hydraulic and chemical cleaning is collected in a common wastewater tank for discharge.
- Periodically X-Flow HFNano Unit can be Membrane Integrity Tested by means of a manual Pressure Decay Integrity Test.
- X-Flow HFNano Unit is equipped with electrical valves, eliminating the need for an air compressor and providing quiet operation.

**FEED WATER QUALITY**

MAIN PARAMETERS	UNIT	TYPICAL RANGE
Color	Hazen	< 100, max 300
DOC	mg/l C	< 10, max 20
Turbidity	NTU	< 5, max 20
TSS	mg/l	<10, max 50
Temperature	°C	0 - 40
pH	-	5 - 9

**PERMEATE QUALITY & PERFORMANCE**

MAIN PARAMETERS	UNIT	TYPICAL RANGE
Color removal	-	> 90%
DOC removal	-	> 75%
Turbidity	NTU	< 0.1
TSS	mg/l	< 0.3
Bacteria removal	-	> 6 log
Virus removal	-	> 4 log
Hardness removal	-	< 10%
NF recovery	-	60 - 75%

**PENTAIR X-FLOW HFNANO UNIT – SCOPE OF SUPPLY & MATERIALS**

Refer to marked boundaries indicated on above process flow diagram on page 2:

- Integrated frame with multiple X-Flow HFW1000 Membrane Elements, speed-controlled crossflow circulation pump, chemical dosing sets for NaOCl, NaOH and HCl, liquid jet pump and electrical heater.
- Integrated piping with manual and automatic electrical valves, flow meters and pressure and temperature sensors.
- Main control panel with Programmable Logic Controller (PLC) for automatic Hollow Fiber Nanofiltration plant operation and control.
- Unit integrated frame : Epoxy coated carbon steel
- Membrane Elements : Polyethersulphone fibers and PVC tubing
- Circulation pump : SS 316
- Main process piping : PVC-U
- Compressed air piping : SS 304
- Cabinets chemical dosing : PE
- Chemical dosing piping : PTFE
- Chemical tanks : PE

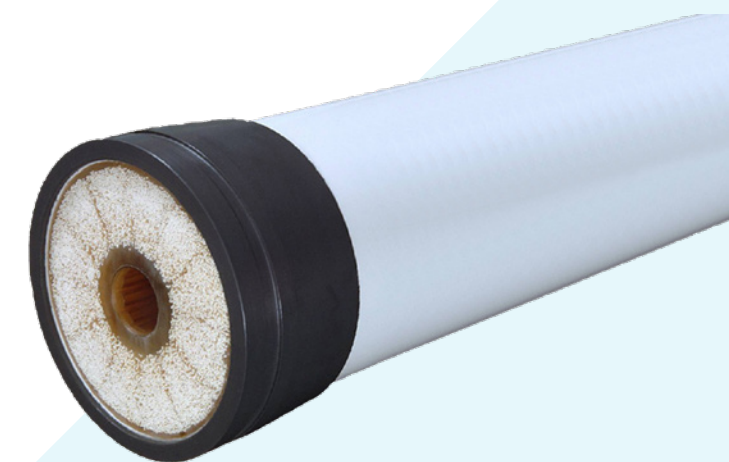

**Pentair X-Flow HFW1000 Membrane Element.**

**X-FLOW HFNANO UNIT – SYSTEM RANGE AND MAIN SPECIFICATIONS 1)**

UNIT NUMBER	NO OF PARALLEL CIRCULATION LOOPS	NO OF HFW1000 ELEMENTS	NF PERMEATE CAPACITY (m³/h)	CIRCULATION PUMP CAPACITY (m³/h @ mwc)	CHEMICAL ENHANCED CLEANING	FOOTPRINT 2) INSTALLED (LXWXH, m)	WEIGHT 3) INSTALLED (kg)	POWER 4) INSTALLED (kW)
HFP003	1	3	1.5 – 2.5	10 @ 21	Common: 5% NaOCl - 5 ltr tank 25% NaOH - 20 ltr tank 15% HCl - 20 ltr tank Liquid Jet Pump Heating Element	3.7 x 0.82 x 1.77	580	6.5
HFP006	2	6	3.0 – 5.0	20 @ 21		3.7 x 0.82 x 1.77	690	6.5
HFP009	3	9	4.5 – 7.5	30 @ 21		3.7 x 1.47 x 1.77	840	7.5
HFP012	4	12	6.0 – 10.0	40 @ 21		3.7 x 1.47 x 1.77	950	7.5

- 1) Reference is made to X-Flow HFNano Unit boundaries in Process Flow Diagram on page 2
- 2) Access for maintenance on 4 sides is advised
- 3) Frame equipped with adjustable feet
- 4) Power installed for circulation pump, electrical heater plus ancillaries. Net power consumption: 0.2 – 0.4 kW hr/m³

**X-FLOW HFNANO UNIT – CONNECTIONS & BATTERY LIMITS 1)**

UNIT NUMBER	FEED (DN)	PERMEATE (DN)	BW (DN)	CONCENTRATE (DN)	WATER FOR CEC (DN)	COMPRESSED AIR FOR MIT (DN)	UNIT DRAIN (DN)	SYSTEM DESIGN SPEC'S
HFP003	50	50	50	50	15	15	50	Overall: Max. 6 barg Max. 40°C
HFP006	50	50	50	50	15	15	50	
HFP009	50	50	50	50	15	15	50	
HFP012	50	50	50	50	15	15	50	

- 1) Reference is made to X-Flow HFNano Unit boundaries in Process Flow Diagram on page 2

**MAIN CONTROL PANEL – SPECIFICATIONS**

For automatic operation and control a Main Control Panel (MCP) is required. Pentair X-Flow HFNano Unit can be supplied with a MCP with the following specifications:

- Siemens® CPU 1510SP-1 PN ET200SP PLC
- Siemens Remote I/O ET200SP consisting of DI, DO, AI, AO cards
- Power distribution motors, pumps, 24 VDC power system and the control system
- Software development according ISA-S88.01
- Ingress protection of the MCP system IP55
- Humidity: 5 to 95% without condensation
- Power supply: 400 VAC +10%/-6% 50 Hz, 3 phase and neutral, earth is separate connected (TNC system)
- Power supply: Transmitters 24 VDC (24 VDC transformer included)



Siemens Main Control Panel.

**MAIN CONTROL PANEL – SPECIFICATIONS**

In addition to the standard Pentair X-Flow HFNano Unit scope of supply, you will need the equipment stated below for a complete Hollow Fiber Nanofiltration process operation. Depending on your specific project requirements, Pentair X-Flow could supply these add-ons as special order. Please consult your local Pentair X-Flow Sales Representative.

UNIT NUMBER	FEED SECTION		BACKWASH SECTION	
	FEED PUMP CAPACITY (m³/h @ MWC)	AUTOMATIC FEED STRAINER	BACKWASH PUMP CAPACITY (m³/h @ MWC)	MANUAL BACKWASH STRAINER
HFP003	4.0 @ 47 9.0 @ 20	(for filtration) (strainer flush) 200 µm	4.8 @ 60	1 mm
HFP006	8.0 @ 47 9.0 @ 20	(for filtration) (strainer flush) 200 µm	9.6 @ 60	1 mm
HFP009	12.0 @ 47 9.0 @ 20	(for filtration) (strainer flush) 200 µm	14.4 @ 60	1 mm
HFP012	16.0 @ 47 9.0 @ 20	(for filtration) (strainer flush) 200 µm	19.2 @ 60	1 mm

- 1) Reference is made to X-Flow HFNano Unit boundaries in Process Flow Diagram on page 2

**CERTIFICATIONS AND STANDARDS**

X-Flow HFNano Unit complies with the following certifications and standards:

- NSF® 61
- NSF® 419
- KTW
- CE certified

**INSTALLATION AND STORAGE CONDITIONS**

X-Flow HFNano Unit must be installed inside a building, in a dry, normally ventilated environment, between 0°C and 40°C, away from sources of heat, ignition and direct sunlight.



**Marssteden 50  
7547 TC Enschede  
The Netherlands**

**P.O. Box 739  
7500 AS Enschede  
The Netherlands  
Ph: +31 (0) 53 428 70 00**

**[xflow.pentair.com](http://xflow.pentair.com)**

All indicated Pentair trademarks and logos are property of Pentair. Third party registered and unregistered trademarks and logos are the property of their respective owners. Because we are continuously improving our products and services, Pentair reserves the right to change specifications without prior notice. Pentair is an equal opportunity employer.

Siemens is a registered trademark of Siemens AG.

NSF is a registered trademark of NSF International.

©2021 Pentair. All Rights Reserved.

Product Datasheet Pentair X-Flow HFNANO Unit V2140